

NEWSLETTER

December 2016



TEL: 021 4773174
FAX: 021 4773184
E-MAIL: INFO@KINSALECOMMUNITYSCHOOL.IE
WEB: WWW.KINSALECOMMUNITYSCHOOL.IE



From the Principals Desk

The past year has seen tremendous progress with the school extension. It is anticipated that we will occupy the new building and gymnasium in March; and we will shortly afterward host an open evening to showcase our new facilities. This is a very exciting time for the community of Kinsale when, at last, the community of Kinsale and its environs will benefit from a state of the art educational facility which is a just recognition for the wonderful teaching and meaningful learning that occurs in our school. By the time that the building works are complete the school will have doubled in size and all prefab structures will have been removed from the site. We greatly appreciate the professionalism and consideration of MMD Construction and their efforts to facilitate us in particular during the State Examinations.

A very exciting additional development has been included as part of the site works, which is the upgrading of our sports facilities to include a two star FIFA accredited all weather pitch and running track. These superb sports facilities are not included within the contract for the extension. The Parents' Association has orchestrated the fundraising for these additional works and I am very grateful to the PA for this initiative. When these facilities are complete, they will provide a magnificent resource for the school and community in terms of physical fitness and health promotion. These facilities will not just have the power to change behaviour in respect of combating obesity and related side effects, they will also serve as a powerful measure in promoting well-being. Please continue to support the PA with their fundraising initiative to see this project through to its completion for all our benefit. The students of the school participated in a sponsored walk on Friday October 28th as a fundraiser for the track and field and they raised 12000 euro. Sincere gratitude to the students, and to all who generously contributed.

The construction works have meant that events, such as the open evening, the musical and the awards' evening, all of which would normally have occurred during this past term, were not possible to host. However, it is envisaged that we will host these events later on in the school year. Our Leaving Cert class of 2016 did us proud, with almost one in four students obtaining in excess of 500 points. Ali Hill achieved a phenomenal result where she

attained the maximum CAO points of 625. Ali, along with Emer Hickey and Ciara Judge qualified for a Quercus scholarship in UCC based on their Leaving Cert results. We look forward to celebrating the success of the Leaving Cert Class of 2016 at our annual awards' evening, which we anticipate will take place in March 2017. We wish each and every one of the class of 2016 every success with their future endeavours.

Our Junior Cert Class of 2016 was also exceptional, with Eve Casey attaining the highest result and we congratulate the entire class on their success.

As well as our students, our teachers have also led the way nationally in terms of continuous professional development. During this past term, the teaching staff organised a series of workshops to share best practice with one another. The Teaching Council of Ireland is seeking to introduce this initiative throughout Ireland, as it believes that this type of collaborative approach to teacher education is the model of best practice in terms of school improvement.

The 2017 BT Young Scientist Exhibition will be held at the RDS in Dublin in early January. Twenty two projects from Kinsale Community School qualified involving 44 of our students. This is a great achievement and we wish all involved the very best.

The Kinsale Ladies' Football team provided great excitement and entertainment as they reached the All- Ireland final which was played in Carlow on Saturday December 3rd. This was a historic achievement; and we are particularly proud of the contribution of our students, past and present, to this success story. A special word of congratulations to past pupil Orla Finn on her historic acquisition of a 6th All-Ireland medal and an All Star Award.

Our senior Camogie team won the County Final on December 6th and we wish our congratulations to all involved especially the team mentors Ms Dwyer, Ms Dunne, Ms O'Donovan and Ms. Leahy.

On October 14th the Kinsale Peace Project organised a Skype interview with Teenage Refugee, Nunjeen Mustafa and a group of TY students. It was a great opportunity for our students to gain an insight into the plight of a young Syrian teenage refugee. As Nunjeen suffers from cerebral palsy and is confined to a wheelchair her strength of character and resilience was inspirational for our students to experience. Our student's very generous response was to raise 400



euro on the day which they presented to the Syrian Trocaire appeal.

I wish to acknowledge with heartfelt thanks all of the friends of our school. These include the Kinsale and District Lions Club, which continues to provide our school with practical assistance and financial support. This ensures that we can provide direct help where it is most needed in the course of the school year. In that regard, I urge you to please support the Kinsale and District Lions Club this Christmas. Such friends also include Eamon Judge for the support, assistance and guidance which he and his colleagues in Eli Lily provide to our Young Scientist participants and Pdraig Fitzgerald of the Kinsale Peace Project. I also want to acknowledge the contribution of local GAA clubs in seeking to improve the good fortunes of our teams. This, Rebel Og supported initiative is being piloted in our school and will benefit our students' physical and social well-being.

I want to extend a special word of thanks to Maria Brosnan for the continued excellence of her work in producing this very impressive publication of the Newsletter. Finally, I want to acknowledge you, the parents, staff and students for continuing to make our school the success story that is. All of you enable us to achieve a wide variety of accolades on an academic, artistic and sporting basis. Truly, our school adheres to its motto, 'All Together in Learning'.

On behalf of the Chairperson, Sr Rita Twomey and the members of the Board of Management, I wish to extend every blessing to you for Christmas and the New Year.

Ba mhaith liom Nollaig Shona agus Athbhliann faoi mhaise a thabhairt diobh go leir.

Fergal O'Gorty

From the Deputy Principals Desk

SUPPORTING ADOLESCENT MENTAL HEALTH AT KCS

Kathleen O'Brien, Deputy Principal

Adolescence is a very challenging time to navigate and KCS we pride ourselves at being ahead of the curve when it comes to supporting the mental health of our young people. We have put into place a rigorous Pastoral Care System which involves weekly Student Support meetings between the Principal, Deputy Principal, Year Heads, Guidance Counsellors, Chaplains, SEN teachers and other relevant staff. We work closely with mental health service bodies where necessary. From SPHE and RSE programmes to the Amber Flag Initiative to regular assemblies to the annual School Walk we ensure that a message of positive mental health is communicated strongly to the students.

A broad and varied extra and co-curricular programme is in place to support the pupils' sense of connection to the school, the community and each other and also their physical health and fitness. Our new fundraising project to develop an astroturf pitch and running track will further improve student access to physical activity and team sport to enhance wellbeing.

Last Year we were one of eight schools in Ireland to work with CAHMS and NEPS to pilot the STEPS-A programme with Transition Year pupils. We are

currently in our second year of delivery of the programme - DBT Skills Training for Emotional Problem Solving for Adolescents (DBT STEPS-A) which is a social emotional learning (SEL) curriculum developed by American psychologists in order to teach adolescents effective emotion regulation, decision making, and problem-solving skills. The DBT STEPS-A curriculum includes 30 lesson plans that are designed to fit within the TY curriculum. Each lesson is 40 minutes long and currently delivered by Ms Niamh Hay and Ms Ita O'Donovan. The curriculum was adapted from the skills training program in



What are the skills?

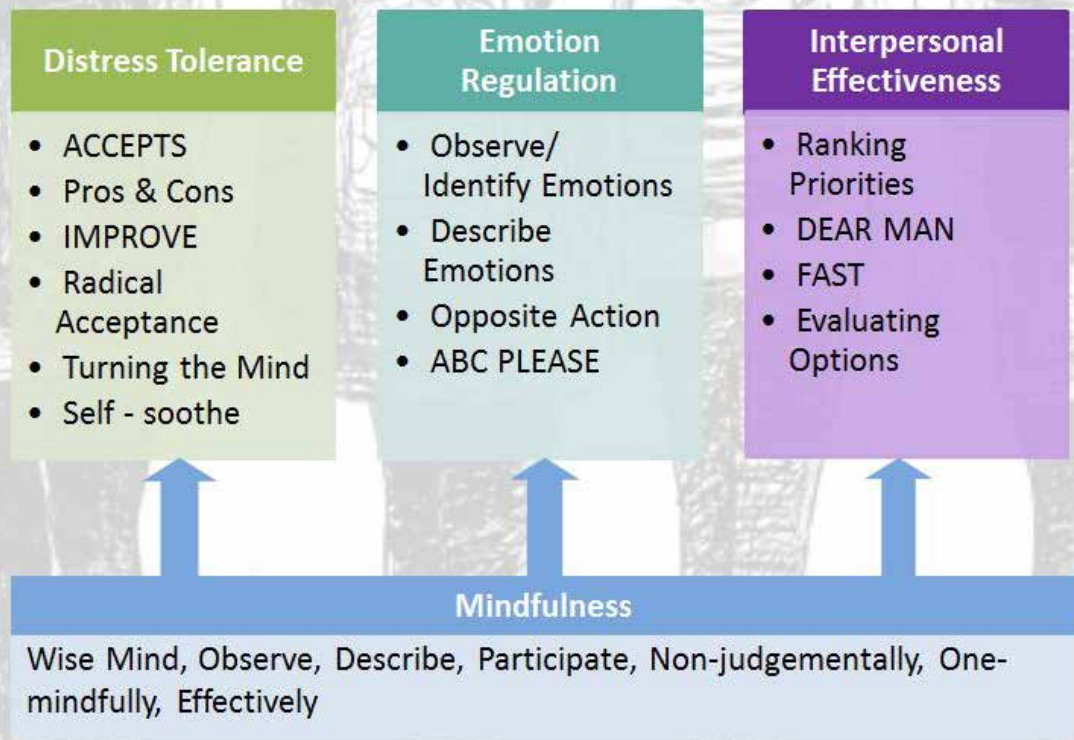

Dialectical Behaviour Therapy developed by Dr. Marsha Linehan, a professor at the University of Washington. The 30 lessons cover skills from each of the DBT skills modules including:

- Orientation & Goal Setting
- Dialectical Thinking
- Core Mindfulness Skills
- Distress Tolerance Skills
- Emotion Regulation Skills
- Interpersonal Effectiveness Skills

Last year pupils found this class to be a totally different approach to learning about wellbeing. They found skills learned to be very useful and found the programme empowering and stabilising in many cases. Pupils enjoyed the

group work involved and also enjoyed experiencing a structured programme in a safe environment with a trusted adult to work around emotional issues. Learning how to manage certain situation and problem solve was very useful, and in some cases made relationships at home function more smoothly!

We continually look to new initiatives in the area of mental health to offer improvements to our service delivery so as to ensure a quality educational experience for our pupils.

OUR SELF-EVALUATION REPORT AND IMPROVEMENT PLAN AT KCS



In the last year, we have looked at teaching and learning in our school to find out what we are doing well. This is what we discovered: The teaching and learning in our school is of an excellent standard and the results obtained by our students in the State Examinations are considerably ahead of the national average. A recent inspection in Geography has underlined this fact. Pupils have access to a wide spectrum of extra and co-curricular activity. The targeted use of resources

towards students with learning difficulties is having a very positive impact in terms of equalisation and inclusion. The collaboration between teachers and the exchange of best practice approaches and ideas has pioneered a practice which the Teaching Council wishes to mainstream.

This is what we did to find out what we were doing well, and what we could do better: There are three areas that the school has identified for research purposes, so as to improve practice. These areas are literacy, numeracy and feedback. Considerable time and effort has been invested in these areas over the last four years. Initiatives have been put in place to interrogate our practices and to identify any shortfalls. Where shortfalls are identified measures are put in place to improve them. This cycle of research, implementation, practice and review is constant as we seek to consolidate our position as leaders of teaching and learning.

This is what we are now going to work on: Our School Improvement Team

continues to work on the three areas of literacy, numeracy and feedback. We are constantly looking at initiatives which we can deploy to offer insight and improvements to these aspects of our service delivery so as to ensure a quality educational experience for the students in our school. This academic year we intend to review our assessment practices.

This is what you can do to help: The improvement of practice is best obtained when you examine the service that you are currently providing. The examination of our service and practice is best achieved through research with our stakeholders and partners. This research is often conducted through the use of surveys and questionnaires. The more who participate in a meaningful way with this research the greater the benefit it will be. We are constantly seeking to improve and your help in this regard is very much appreciated.

HERE IS SOME INFORMATION ABOUT HOW WE ARE CARRYING OUT OUR WORK AT KINSALE COMMUNITY SCHOOL AND ABOUT WHAT THE DEPARTMENT OF EDUCATION AND SKILLS (DES) REQUIRES US TO DO.

SCHOOL TIME AND HOLIDAYS

The Department requires all post-primary schools to have 167 school days each year, and a 28-hour school week. This year we will have planned for 167 school days, from Monday August 29th 2016 to Friday June 2nd 2017. Our school week is 28 hours per week with 42 40-minute lessons.

The Department sets out a standardised school year and school holidays.

This year we took all our school holidays within the permitted time.

The Department sets out arrangements for parent/teacher meetings and staff meetings. This year all of our parent/teacher meetings and our staff meetings were organised in line with the Department's regulations.

Looking after the children in our school The Department requires schools to follow the Child Protection Procedures it has set down. Our board of management has agreed in writing to do this. All teachers know about the Procedures and we have told all parents about them and how we follow them.

Our Designated Liaison Person (DLP) is Fergal McCarthy and our Deputy DLP is Kathleen O'Brien.

ENROLMENT AND ATTENDANCE

The Department requires schools to have and publish an admissions policy, to record and report attendance accurately, and to encourage high attendance and participation. We have an admissions policy and it is published. We periodically review and update our admissions policy.

We keep accurate attendance records and

report them as required.

We encourage high attendance in the following ways: Teachers take a register at each class on the e-portal system. Contact is made with home by the Year Head if a pattern of absence is identified. This is how you can help: Please provide notes detailing any reason in respect of absences. Please ensure your child attends school on a regular basis.

POSITIVE BEHAVIOUR FOR A HAPPY SCHOOL

The Department requires schools to have a code of behaviour, and asks us to consult parents and students about it. We do this.

Our code of behaviour describes and supports positive behaviour.

We have a very clear and high-profile anti-bullying policy in our school.

FÉILTE BEAGA, SHARING AND LEARNING TOGETHER

Féilte Beaga is Kinsale Community School's unique teaching initiative which pioneers sharing educational practices with each other. Our second Féilte Beaga took place on 5 October 2016, World Teachers' Day.

It is inspired by Féilte- the Festival of Education in Learning and Teaching Excellence- which is held annually in Dublin.

Staff members led a series of workshops about innovative teaching methods, which leads to more interactive learning.

The student council was represented at the event by Niamh Twomey, Head Girl, and Tadhg McCarthy, Head Boy. The principals of local primary schools attended the event, along with Tomás O'Rourke, the director of the Teaching Council, Joan Russell of ETB Ireland and Sr Rita Twomey, the chairperson of the school's board of management, as well as members of the Education department of UCC. Our school was also chosen to showcase our initiative at Féilte in Dublin. Teachers Leona Forde, Ger Hogan and Joanne O'Connor facilitated a workshop at the national event to promote continuous professional development. Mr McCarthy, our principal, also attended.

It is our second year of participating, following on from Ms O'Brien, deputy principal, Cathy Hynes and Eve Casey's appearance on a panel to discuss the role of ICT in education last year.

Ms Leona Forde,
Coordinator of Féilte Beaga

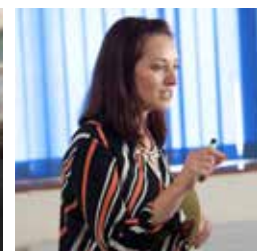

KINSALE COMMUNITY SCHOOL TEACHMEET

On Tuesday the 15th of October 2016, the staff of Kinsale Community school held its first ever Teachmeet. A Teachmeet is an informal gathering of teachers who meet together in their free time to share good practice, practical ideas and resources that they have used in their classrooms.

Teachers have a choice to either present an idea or simply relax and listen.

On the day three teachers presented, showcasing ideas on feedback, peer editing, and motivation. The ideas shared were creative, interesting and fun. I myself left with some great practical ideas I could use in my classroom.

The Teachmeet not only provides us with a space in which to learn from each other but also affords an opportunity for trainee teachers, newly qualified teachers and experienced teachers to offer advice and

support to each other.

A huge thanks to all presenters and attendees, all of whom helped in making it a success. Our next Teachmeet is planned for January and I look forward to it with much anticipation.

Ms Leona Forde



En vacances en France!

The French exchange group of 29 enthusiastic Francophiles headed off into the unknown in October last as they boarded their flight to Nice. The enjoyment of the flight was replaced two hours later with nerves and apprehension in Nice airport as students were greeted for the first time by their French exchange partners before everyone disappeared into the evening sky in Renaults, Peugeotts and Citroens!

After a maximum of 6 hours sleep we met at Lycee Audeberti where the relief to be back with familiar faces was tangible. We spent the day in beautiful Nice where for centuries Northern Europeans have wintered appreciating the frost and damp free climate and walking along the aptly named 'Promenade des Anglais'. Here we took a walking tour through the town and up to the castle which is perched on Nice's highest point with panoramic views of the Nice coastline. Many also visited the scene of the July 14th terrorist attack which left dozens dead. The flowers and toys on the footpath stand as a poignant reminder to the recent atrocity.

Next day we met 'a la gare' and boarded a train for Monaco. The stunning vistas of the Cote d'Azur coastline were greatly appreciated as we made our way along what must be one of the most spectacular train journeys in the world.

Monaco's aquarium founded by Prince Reiner was the highlight of the morning while later our walking tour took us (in torrential rain!) through the winding streets of the old town past the Royal Palace and the Ramparts with views over the city with the highest real estate values in the world. We looked enviously at the yachts, mansions, Ferraris and of course noticed the Grimaldi name emblazoned on everything from ships to banks.

A full day in Cannes had to be curtailed due to the storm which had covered the whole of southern Europe. The rain was tropical and only for the indoor market we would have been reduced to a pitiful state. Nonetheless we saw the Footpath of the Celebrities with its handprints of famous actors and the theatre where the famous Cannes Film Festival is held as well as

indulging in some retail therapy which is even more necessary in such inclement conditions.

Time in school was limited to short periods in the early morning and late evening due mainly to the fact that like ourselves they too are in the middle of a major building project but also due to the new strict security regime which has resulted in every public building being secured like a fortress.

After a weekend 'en famille' we headed for the airport for our short flight home. Memories of the visit will stay with us forever and we look forward to the return of our partners in March next when we will hope to match the welcome given to us by the French families.

A Bientot
Mr Tony Cierans





FUNDRAISING WALK

Pictured are students, staff and volunteers who took part in the sponsored walk on Friday 28th October to help raise funds for the new all-weather pitch and running track. It was a wonderful day and students enjoyed the team-spirit of the event. Well done to all involved!

We would like to thank Margaret Murphy for her work as Safety Officer, the Civil Defence for marshalling on the day and Ms Niamh Hay for co-ordinating the event. We would also like to take the opportunity to thank Martin Ryan, Rhino Print Kinsale for generously sponsoring the fundraising cards.









Leaving Certificate Applied

LCA students have had a very busy first term to date. The students received their Session 2 Results in September; these indeed reflected the high quality of work of students and their teachers.

An underlying principle of the LCA Programme is numeracy and literacy development. This takes place on an ongoing basis and in a variety of contexts. LCA teachers are constantly seeking innovative and enjoyable ways to continue to do this. Board games, darts, roulette, card games have been used in class to assist in helping to embed numeracy concepts such as probability, problem solving and logical thinking.

Voting and elections are the selected Research Topics for this year's Mathematical Applications Leaving Cert Examination. This involved developing an understanding of the complex language of election such as quota, valid poll, first count, spoiled votes, surplus, transferable votes and register of electors.

As a result of this LCA students are being moulded into socially responsible citizens as they now understand the concepts of

elections and democracy. Indeed one class member is now putting this into practice as a representative on the Prefect team

The class were also involved in the organisation and monitoring of Student Council elections.

The concepts of logical thinking and effective time management are also being used by student in their Task preparation. This term they are working on a further three Tasks in the areas of Graphics and Construction Studies, Contemporary Issues and Practical Achievement.

All students attended Open Days in the Cork College of Commerce, Coláiste Stiófán Naofa and St John's Central College with their Guidance teacher where they were able to learn about Courses of interest to them and speak directly with staff involved in these courses.

Students have also sampled the world of work while completing work experience and we are fortunate to have the continued support of local employers to facilitate this vital experience again this term.



College Calling

Leaving Certificate Applied students visited four different Colleges of Further Education as part of their Guidance module. They visited Kinsale College of Further Education, Cork College of Commerce, St. Johns Central College and Colaiste Stiofain Naofa to explore the broad spectrum of career and training opportunities available to them as progression from the Leaving Certificate Applied programme. Students were very impressed with the different colleges and enjoyed the brief introduction to college life along with catching up with some past students from KCS.

ALLONS AU CINEMA.....

188 First Year students celebrated their first month of studying French with a visit to Actons Hotel where the ballroom had been transformed into a cinema for the day. We watched a special screening of the classic French tale Asterix and Obelix starring none other than France's most famous actor Gerard Depardieu. Despite being in French with English subtitles the students enjoyed the experience and their laughter was loud despite competition from the crisp and sweet eaters (who make a trip to the cinema ever so enjoyable!!!).

The student's behaviour was exemplary and their politeness was complimented on by the hotel staff. Special thanks to Mr Brendan Barry and Ms Kathleen Fitzpatrick for constructing and painting the screen. And thanks to the students of Transition Year and to Ms Hay for their technical assistance. The French Dept will continue with its programme of cultural activities with a Table Quiz and French Breakfast before Christmas.

Tony Cierans



CAMOGIE

SENIOR CAMOGIE: COUNTY CHAMPS!!!

Huge congratulations to our senior camogie team on winning the County Championship. They played superbly against Carrignavar in the final, with an end result of 4-6 to 1-5. We are immensely proud of the girls and credit them for their hard work all year. Well done to Clara Mulcahy who captained the team to success.

We would like to take this

opportunity to give a special mention to all of our 6th year girls who have played for the school since first year and have always given their best to the team. Your dedication and enthusiasm is commendable.

JUNIOR CAMOGIE:

Our junior team have performed excellently so far this year. We are due to play in the final of the County Championship against Hazelwood Dromcollogher in early 2017.

In the Munster Championship we defeated Laurel Hill of Limerick, 8-9 to 3-5. We are due to play St. Angela's Waterford in the second round of the Championship in late December.

FIRST YEAR CAMOGIE:

We'd like to applaud our first year girls for their interest and participation at training since joining KCS. They had a fantastic day at the Glanmire Blitz in October, making it into the semi-final.

The first year league begins in January and we look forward to future success with them.

Huge congratulations to all of our camogie players here at KCS and wishing you all continued success for 2017.

Ms Dwyer, Ms Dunne, Ms O'Donovan and Ms Leahy



Senior Camogie Team



Clara Mulcahy Senior Captain



Junior Camogie Team



Y1 Camogie Team



FOLLOW US ON TWITTER!

- KCS Main Page – @KinsaleComSch
- GAA - @KinsaleCSGAA
- Golf – @kcs_golf
- Soccer – @kcssoccer11
- Basketball - @KCS_Basketball
- Anti-bullying Campaign - @kcsantibullying
- Architecture - @KCSarchitecture
- ASD - @ASDKCS
- Camogie - @CamogieKCS

World of Work

The first week of TY work experience took place at the end of November. Work experience is a great opportunity for students to gain an insight into the world of work as well as enabling them to make better decisions regarding career possibilities and subject choices. They also learn new skills, increase self-confidence and make useful contacts.

Prior to work experience students prepared

curriculum vitae and cover letters. Many students were also interviewed by employers before successfully securing a place.

Comments from students following the week were that they enjoyed the experience immensely. Although many found it exhausting, some admitted they were a little bored and that they really missed their friends. Most have a brand-new appreciation for their life in school. Some students have found their niche and some found their nemesis but all

agreed it was an extremely worthwhile experience. Some students were even successful in securing part-time jobs and we received numerous glowing reports from employers.

KCS would like to take the opportunity to thank all of our employers for providing our 161 TY students with work experience. The students will return to the world of work in February for another two weeks and we hope employers will be equally generous with their time, expertise and of course patience.



ECDL

Each year, as part of Transition Year in Kinsale Community School, students undertake the ECDL (European Computer Driving Licence) programme. This is an online computer-based subject which consists of 7 modules. The New ECDL programme is now in its third year at Kinsale Community School consisting of newer updated modules along with core modules –

- Computer Essentials
- Online Essentials
- Word Processing
- Spreadsheets
- Presentations
- IT Security
- Online Collaboration.

This year students also have the opportunity to study extra modules including Databases, Computational Thinking, Digital Media, Microcontrollers and Multimedia Storytelling.

The ECDL Programme is an extremely beneficial programme which provides

students with the opportunity to broaden their knowledge and skills in computer technology. Upon successful completion of all 7 core modules, students are awarded a Certificate in ECDL which is an internationally recognised qualification. A highly valuable asset to any CV!

Well done and congratulations to the students of TY 2015/2016 and their teachers Ms. Brosnan and Ms. Mullaney.

Pictured are some of the TY students of 2015 - 2016 who were presented with their ECDL Certificates by the ECDL Co-ordinator, Ms. Brosnan.



BT Young Scientist Exhibition

Kinsale Community School has qualified a massive 22 projects for the exhibition in January. This is our second best representation in the exhibition. There will be a total of 44 students travelling to the RDS and a huge amount of work is being carried out.

The exhibition runs from the 11th to 14th of January.

NATIONAL ARCHITECTS IN SCHOOLS INITIATIVE

The National Architects in Schools Initiative at Kinsale Community School had a very successful year in 2015.

This culminated in Mr. Cathal O'Donovan being invited to speak to a gathering of architects and teachers at Charleville Castle in Co. Offaly to outline his and the schools very positive experience with the Irish Architectural Foundations program.

In attendance was Mr. Duncan Stewart who presents "About the House" and "Eco Eye" who gave a very informative talk on the environment and the benefits of passive housing.

The NASI program is being run again this year in Kinsale Community School with local architecture firm Conneely Wessels

Architects who are located in Kinsale town.

We are looking forward to a very exciting, interesting and inspiring year of looking at the benefits of architecture for both the built and natural environment.



Mr O'Donovan & TY students with Conneely Wessel Architects Kinsale

Friendship Morning

A friendship & well-being morning for all first year students took place Friday morning the 18 November. Fifth Year Meitheal students ran various activities encouraging friendship and teamwork among our seven first year groups. Activities included Human Bingo, a 'Random Acts of Kindness' poster competition and the very competition A-Z Friendship Challenge.

Well done to our Meitheal students David Graham, Andrew McCarthy, Hugh Ward, Jake Hyland, Clodagh Butler, Holly McVitty, Isabelle Fitzgerald, Grace O Leary and Niamh McCarthy for running the activities with each of the first year groups.

Fun, teamwork and bonding was had by all!

Ms O'Carroll



MSD Visit

On Monday the 14th of November 60 transition year students took part in a science talk as part of science week. The talk was hosted by a number of employees from MSD in Brinny. This plant specialises in the ‘fermentation, purification and sterile filling of biotech products including two of the company’s most successful treatments for hepatitis C and rheumatoid arthritis’.

Following the talk, six students were selected by MSD to take part in a visit to their plant to learn more about what they do. I was one of the six chosen along with Mia Hynes, Aoibhinn Lynch, Cathy Hynes, Grace Hurley and Alec Schmidt. Our teachers Ms. Hay and Ms. Brosnan accompanied us and when we got there we went through a short safety briefing and were then shown to our base room.

We had a number of speakers from employees one of which included Barry Mulcahy who talked to us about the importance of health and safety and hygiene. He also spoke to us about the business side of MSD and how they have to report all the small problems with their products.

We met students from other schools and went through some ice breakers to get to know each other. We were also told a little bit about MSD’s products. Finally, we were given a tour of the plant – we even had the chance to look into the windows of labs and watch what was happening in each one

When we returned to our base we were



treated with a lovely meal and mingled with other students. Afterwards we were divided into two groups – one took part in a quiz and our half took part in a tour of the plant. We were so excited but also



surprised to learn about the emphasis on health and safety. We were instructed to hold the handrails going up and down the stairs and had to follow particular walking paths. When we arrived at the labs we put on safety shoes, lab coats and glasses and then entered the lab where we learned a bit about them. It was a very interesting and eye-opening experience and by the time we left the labs we appreciated how important health and safety is in this



environment. When we arrived back to our base, the groups swapped over and we took part in a quiz while the other half went on the tour.

It was a very enjoyable day and we learned a lot about the various areas of science and the types of career possibilities.

Olivia Keohane (TY)

KCS Chess Club

In September the KCS Chess Club was re-ignited after a couple of years break.

Ms. M. Fleming invites anyone interested to come along to CO1 every Tuesday lunchtime to get involved in the Chess Club. Since it has started numbers have grown and grown each week. It is great to witness younger students teaching older student tips and tricks of Chess and vice versa. Whether you have or have not

played Chess before, you are invited to come along and give it a go.

As well as it being very enjoyable, playing Chess has many other benefits too, for example it is proven to raise one’s IQ, it exercises both sides of the brain which improves creativity, Chess is known to improve memory and in cases has been attributed to preventing Alzheimers.



GÆILGE

CLUB GÆILGE

Club Gaeilge is run by Transition Year Students in conjunction with Ms. Murray. The club aims to support and encourage First Year Students with their Irish language through games, quizzes and other fun activities. The club is on every Monday at lunchtime and all first year students are welcome.



IRISH DEBATING

Well done to Cathy Hynes, Grace Hurley and Olivia Keohane from Transition Year who recently participated in the Gael Linn Irish Debate which was held in Crosshaven. The girls excellently debated the motion that the Olympic Games should be done away with. Ms. Murray would like to thank the girls for their hard work and dedication in researching the motion and practising their speeches. They represented the school excellently.



GÆLBHRÁTACH

Níl bréag a rá go bhfuil grá ollmhór don Ghaeilge sa scoil seo. Déanann go leor daltaí anseo iarracht den chéad scoth isteach an teanga a úsáid go rialta .

Ag tús na bliana ,bhí sé ar intinn ag na múinteoírí Gaeilge agus na scoláirí, Gaelbhreatach a fháil don scoil. Taispeánfadh an bhratach seo an bhéim atá ar Ghaeilge sa scoil.

Chuaigh mé, Cáit Ní hEidhin (OCP) agus Sinéad Ní Mhurchú (Rúnaí) go cúrsa traenála chun coiste a chur ar bun. Bhí sé suimúil go leor agus d'fhoghlaimíomar a lán rudaí nua.

Anois tá an coiste ag obair go dian ar ár bplean gnímh. Caithfidimid fis a dhéanamh agus rudaí mar sin. Ar an 17ú Samhain, bhí Gaeilge 24 againn agus bhain gach uile duine a bhí páirteach an-sult as an eachtra! Tá club Gaeilge ar siúl don chéad bhliain freisin. (Táimid an-ghnóthach!!!)

Tá súil againn go mbeidh níos mó eachtraí spraoiúil ag tarlú i Ruth na bliana nua. Bígí linn and bígí bródúil as bhur nGaeilge-is leatsa !

Eve Ní Chathasaigh
-Cathaoirleach

GÆILGE 24

Ar an 17ú Samhain, ghlac os cionn 30 dalta ón Idirbhliain páirt i nGaeilge 24. Dúshlán náisiúnta is ea Gaeilge 24, eagraithe ag Conradh na Gaeilge, chun an Ghaeilge a chur chun cinn i measc dhaoine óga na tíre. Thug gach éinne faoin dúshlán le fonn is le díograis. D'fhreastail na scoláirí ar a ngnáthranganna i rith an lae, ach ghlac siad páirt trí mheán na Gaeilge! Mata trí Ghaeilge, Fraincis trí Ghaeilge, Adhmadóireacht trí Ghaeilge!! Bhaineadar idir thaitneamh is thairbhe as!

Over 30 TY students participated in Conradh na Gaeilge's national challenge Gaeilge 24 on 17th November. The aim of this initiative is to inspire young people to speak Irish for 24 hours at school, at home, in their towns, in shops and everywhere possible. With the support of staff as well as students from other year groups, the students set about the challenge enthusiastically, and there was Gaeilge to be heard go flúirseach throughout the school!

Ms D. Dempsey



STEPS TO SUCCESS

On Monday 17th October TY enterprise students travelled to the Celtic Ross Hotel, Rosscarbery with their teachers Ms O'Donovan and Ms Brosnan to attend the 'Steps to Success Student Conference'. The event was opened by Kevin Curran, Acting Head of Enterprise, Local Enterprise Office Cork North & West and MC'd by Christine Heffernen. It was a very busy event with over 380 TY students from all over West Cork in attendance! It was an eye-opening and interesting experience for the enterprise students who listened to a variety of speakers from various business backgrounds. It also provided students with an opportunity to learn about various aspects of enterprise.

Guest speakers included Breffney O'Dowling Keane who spoke to students about her journey to becoming a young entrepreneur with her business Fruit Cubed. Her products are fruit based stock cubes which utilise waste and over-ripe fruits to produce a product with an extended shelf life which delivers a tasty, innovative, nutritional solution. Breffney

spoke about her passion for food and the importance of having a love for the business you are in. Next up was Neil O'Driscoll from Platform Avenue who spoke about 'The Eureka Moment'. Neil discussed his work in the engineering industry before experiencing a 'eureka moment' and returning to college to study software development. Today, Neil runs a talent management company with his business partner Patrick Dineen. After a short interval, Paul Delaney (Artist) spoke about turning a talent into a business and was followed by David Hyde of the Patents Office. David spoke

about the technical aspects of business and informed students about patents and copywrite. Finally the conference came to a close with speaker Damien Mulley who spoke about promoting business online.

Overall it was an interesting, enjoyable and educational experience for the students. Best of luck to all mini-company students in their mini-company projects and in their preparation for the Student Enterprise competition early next year.



1st Year Soccer

In our first competitive game, we travelled to Ballincollig to play a strong Colaiste Choilm team. Our boys travelled with a game plan and perfected it to a tee and came away with a deserving 1-0 win courtesy of a wonder goal from Peter O'Sullivan.

Our next game is against Skibbereen on the 8th of December. We look forward to playing football in the New Year and progress to the latter stages of competition. Follow us on twitter @KCS soccer to watch our progress.



Golf

In September the Senior Golf Team of Eric Rumley, Ben Costello, Jody Costello, Harry Sheehan and Andrew O'Connell came second in the South Munster qualifying section of the Munster Senior Championship at Fermoy Golf Club. In October at Douglas Golf Club KCS faced a tough test against Douglas CS in the Munster quarter final and lost narrowly 3-2. The team are to be commended for their attitude and performance and it is fair to say that the future of golf in Kinsale Community School is in safe hands, with four of the five team members in third year.

We wish Ben and Jody Costello well over the winter months as they prepare for next season with the Munster U-16 development squad.



BALLYHASS LAKES

DAY 1:

On the first day, the excitement began when I boarded the bus for Ballyhass. The journey was much longer than I expected, and after we had finally passed Mallow, I had no idea of where we were! I felt as lost as I would be in another country. When we finally arrived at Ballyhass, we were divided into groups, and taken to our first activities. The first activity I did was wilderness, where we had to build a shelter from sticks and leaves, and make a fire. I was lucky that I brought a raincoat, because the instructors poured a five litre bottle of water over our heads! This was to a test to ensure our shelter was waterproof. Needless to say, I needed that raincoat!! Next, we headed to the lake to do kayaking. This was my favourite activity; it was my first time kayaking, and it definitely won't be my last. I had fun paddling around the lake and jumping in! The water was freezing cold, but I was glad there were hot showers to jump into after. The final activity of the day was zip-lining. Zooming at a fast speed suspended by a thin cable over a freezing lake was definitely a great experience. When we had finished zip-lining, it was time to call it a day so we wearily boarded another bus to our accommodation in Sunfort about 30 minutes away. On arrival we were greeted with warm smiles, as we dropped our bags to our rooms. We had little time to prepare ourselves before dinner was ready - not that anyone cared, we were all starving! Later in the evening we all gathered together in front of a crackling fire to participate in a table quiz. After



the winners were announced we returned to our rooms to get some rest - I knew there was no point in staying up, because I would need all my energy for tomorrow. (Alec Schmidt)

I was up at the crack of dawn on Wednesday morning and unfortunately I was absolutely wrecked! It was probably from the build up to the actual day, but, I must admit I was a mixture of being both nervous and excited all at the same time. My bag was quite heavy and bulky from all my clothes and snacks of course! One could easily assume that fifty per cent of my bag contents were food! Once we all hopped on the bus, we sang and chatted the whole way down to Ballyhass. Much to our teachers delight!! Once we arrived, we all dropped our bags off into the drop-off room and we all gathered together in the lunch hut area. We were then divided into our groups and luckily I had most of my friends with me. Our first activity was team challenges on an obstacle course called the low-ropes. It was really enjoyable and funny to watch the lads mess up over and over again! After the low-ropes we moved onto the swing rope and swung the day away! We then had lunch before heading off to do wilderness in the forest for the rest of the evening! The highlight of the wilderness was toasting the marshmallows at the end! Yummy!! (Jennifer McCarthy)

DAY 2:

A late night and early start today left students looking tired and overworked (no different to usual I suppose!). But today wasn't the day to be tired as we pulled on our wetsuits and went wakeboarding and on Ringo rides. This was an incredible experience for me as someone who already loves the sea and has tried every other water sport there is! There was no surprise on my behalf when I took easily to the wakeboarding and it now looks like a sport I will pursue for fun in the future. After lunch we attempted team



building exercise but to little or no avail. Following this we raced hurriedly back to the centre to learn about the next few activities facing us that day – zip lining, rock-climbing, abseiling and archery. My confidence and new dauntlessness showed again as I eagerly offered to go first in each and every new obstacle thrown towards us. The evening had to be one of my highlights of the trip. We began the by learning to use various Irish instruments like the bodhráns and the spoons, this was shortly followed by entertaining displays of talent from the more courageous of the group. Subsequently, the moment we had all been waiting for... the most famous event of the TY calendar ‘Miss Ballyhass’. It will be an event we will remember forever! Now I can’t give away too much or spoil the surprise for future contestants – you’ll just have to experience it for yourself! (Anon)

Our second day was a mix of water and land based activities including raft building, kayaking, zip lining and climbing. The morning began with raft building and once we had finished constructing our raft we took it out on the lake and hopped in our kayaks. Our raft was quite sturdy as some of us knew how to tie a good knot! We played some team games and raced each other. I think everyone fell into the lake at least once – I of course managed to fall in twice! After lunch we began on the climbing frame. We each took turns trying our best to ascend ‘The Gladitator’. Most of the group made it all the way up, but unfortunately I could just about get halfway. Personally, I think the wind caused it because I could have done it, I swear! After a tiring day of activities we returned to Sunfort to replenish our energy with burger and chips! Tonight was a busy night of musical talent – we played the Bodhrán, the spoons and even sang a song or two. This was followed by Miss Ballyhass – a talent contest which was one of the funniest things I have ever seen in my life! What an end to a fantastic day! (Georgia Collins)

DAY 3:

On the last day we began the daunting task of packing our bags, stripping our beds and cleaning our rooms before boarding the bus. We said goodbye to our lovely hosts and returned to Ballyhass for our last day of activities. My first activity of the day was raft building. This was one of my favourite activities - after building our masterpiece we all had to carefully place ourselves on the raft to try and avoid it sinking. However, there’s always one who



wants us all to end up in the water. One of my group members stood up and our raft suddenly transformed into a scene from the Titanic with us all half submerged in water and clinging on as it tipped into the sky! After that we went kayaking which I loved. Our last activities of the day included daring tasks such as zip-lining and abseiling. My favourite was zip lining as I loved the speed going over the lake. We also had the chance to try out some archery but I must admit it wasn’t really for me. It was sad to say goodbye but we were all overjoyed to be reunited with our phones after nearly three days of abstinence!! (Aoife Kelly)

It was our last day in Ballyhass. I was absolutely gutted that we were leaving because I enjoyed myself and challenged myself so much in these past 3 days. The first activity we completed was ‘The Gladiator’ which was a climbing course hanging in the air meters above ground. It was quite competitive and I had to race my friend Sarah to the top – much to my delight I won and my instructors nicknamed me ‘rapid spider monkey’. We also had the opportunity to experience wake boarding and ringos. Wake boarding was literally like snowboarding but in water. Participants were dragged along the water by a wire that you held onto. It required a lot of concentration and co-ordination but I picked it up quickly and my instructor Tarren increased my speed to 7/10. Afterwards, Sarah and I then hopped onto the ringos together (this was an inflatable cushion that you had to hold on to as it got dragged across a wire). It was so funny, poor Sarah fell off! I was really sad saying goodbye to all of the instructors who guided us and mentored us over the three days but it was a fantastic trip. The highlight for many of course was the trip to McDonalds on the way home!!

We would like to thank all of the teachers and SNA’s who accompanied us over the week including Ms Hay, Ms Brosnan, Mr Hayes, Mr Duggan, Ms Woulfe and Ms Moran. (Ceara Dhingra)

REFLECTING ON BH LAKES

“I had mixed feelings about this at the start as I was separated from my friends but looking back in hindsight this was a smart move as it put me out of my comfort zone and helped me make new friends. We went on the zip line it gave me such an adrenaline rush when I was

flying through the air over the lakes; I don't know if i was screaming with joy or fear but I loved it!" – Darragh Mangan

"I really challenged myself extremely especially with heights, I learned to trust and cooperate more and I definitely became closer with my year group. The trip was amazing and the activities were entertaining. I definitely would do it again!" - Ceara Dhingra

"I loved my trip to Ballyhass and would put it as one of the many highlights of my TY year so far. I think it was a great experience and time to put yourself out of your comfort zone and also to make new friends and get to know the people in your year a bit better". - Aoife Kelly

"Looking back on my experiences at Ballyhass Lakes, I can certainly conclude that I had an absolute brilliant time! The day before the trip, I went to Wilton Shopping Centre to stock up on snacks and necessary items needed for the three days. The snacks were without a doubt a survival requirement! Overall, I must say that it was a very worthwhile trip and I would do it all over again in a heartbeat. I made so many new friends. It was certainly a great confidence booster and I can only say I benefitted from it all". – Jennifer McCarthy

"This really was an incredible experience and one I would encourage everyone to do. I returned home and told my parents that it had been the best few days of my life and that I couldn't believe the hugely positive things I learned about myself and the confidence I gained". - Anon



Athletics

First Year students travelled up to the athletics track in CIT with their teacher, Mr. Cathal O' Donovan to take part in the Munster Schools Combined Events Competition on Wednesday the 5th of October.

The competition required students to take part in hurdles, long jump, shot putt, high jump, 200 metres and 800 metres.

The students had a great experience of competing against schools from all over Munster and one of the highlights was Ava Coyle coming second overall and winning a silver medal.



The next fixture for Kinsale Community School athletes will be Schools Challenge Cross Country race in Cork Institute of Technology on Friday the 9th of December.

Junior/Senior Boys Basketball

The Junior and Senior Boys Basketball teams have been competing in the Cork school league since the beginning of the school year. In all, both teams played three group games throughout September and October including outings with Glanmire, Carraig na Bhfear and Crosshaven. Despite some tough opponents, Kinsale earned some great victories along the way and represented the school admirably.

After qualifying from the group stages, both KCS teams were matched up with Coláiste Spioraid Naomh of Bishopstown in the quarter final stage of the competition. After leading for most of the game, our Junior team were very unlucky to come up short by three points in a closely contested game. After dominating the first half, KCS ran out comfortable winners in the senior game and progressed to the semi final stage where a match up with Crosshaven awaited. Unfortunately, after a highly competitive game, KCS lost out by six points despite an outstanding fourth quarter in which they outscored Crosshaven 12 – 4. Well done to all involved for a thoroughly enjoyable season.

Hamlet

Sixth Year English students visited Charles Fort for a promenade performance of 'Hamlet' by a group of young, enthusiastic and talented actors from Kinsale College. Students and staff were extremely impressed by the quality of the acting and the seamless transition of each scene. The physical setting of the performance, in such an iconic, local setting was most enjoyable.

Although this was an abridged version of the play, the players presented us with well-developed characters; from Claudius's cunning, intelligence and ruthlessness to Hamlet's passion and sense of injustice, the audience were immediately intrigued. This was an educational and valuable experience. Many thanks to Kinsale College for the performance.



Woodwork and Construction Studies

The Woodwork Department has once again been very busy since the start of the year. Some of the projects that have been made by the First Years this year are Teapot Stand and Bird Feeders. The First Years have been very enthusiastic about the subject and are looking forward to making Christmas decorations to display in their homes over the Christmas period. The Second Years have continued the nature theme as they are currently in the process of building Bird Houses that they will be able to display in their gardens when finished.

The next project they will be completing before Christmas will be Christmas Lamps that will be able to light up.

The Third Years are presently working on planning their Junior Certificate projects before beginning the construction of them in Room E01.

The Transition Years have made numerous Woodwork projects including Key Holders, Teapot Stands and Egg Holders.

The Fifth Years studying Construction

Studies are busy exploring the various parts of a domestic house and produce detailed sectional drawings of the different parts of a house.

The Sixth Years are busy working on their Leaving Cert projects which include 3D models of houses and furniture.



Christmas Food Appeal

The TYs as part of Ms. M. Fleming's Religion class have organised another Christmas Food Appeal this year. We are asking for staff and students to donate any non-perishable foods for example, tinned foods, pasta, rice, cereals, chocolate, porridge, noodles, soups, selections boxes etc

This campaign has gone from strength to strength each year, with us being blown away by people's generosity and kindness, and we are hoping this year will be no different. We would like to say a big thank you to Smiths Centra in Kinsale for allowing us to borrow a shopping trolley again this year. All donations contributed will be given to Cork Lions Club on the run up to Christmas Day. The foodstuff will then be distributed to those most in need living homeless or to families in need throughout Cork.

Help make someone's Christmas a little special this year by kindly dropping food into the trolley at reception.



HURLING REPORT

2016

UNDER 16 HURLING

Our under 16 hurlers competed in the Cork PPS 'A' quarter final in October where they faced a strong Colaiste Choilm outfit. The match was played in Carrigaline and although our lads started brightly but were unable to convert pressure into points. Our opponents grew into the game and proved to be more clinical in their shooting. With a flurry of scores in the final 10 minutes, Colaiste Choilm ran out winners own a score line of 3:15 to 2:09. There were strong performances from Faelan Steward in the backs and Aaron Lyons in the forwards who scored 2 goals. The under 16 and a half hurlers were out a week later with a young team which was very similar to the under 16 team who out-muscled the previous week. We were competing in the Munster 'B' PPS competition and our opponents were CBC Cork, the match was once again played in Carrigaline. The much more experienced CBC side took a well-deserved victory; however from our point of view there were many players who put their hands up for selection with the senior team, namely Ryan Long, John O'Brien, Tom O'Connell and the impressive Aaron O'Mahony in goals. Great work was put in by Mr Leahy and Mr Madigan in preparing these two teams for their fixtures.

SENIOR HURLING

The senior panel led by captain Cian O'Mahony were the first hurling team to play a competitive fixture this academic year when they competed in the quarter-final of the O'Callaghan Cup on October 10th in Carrigaline. Here, we faced a very strong opposition in the form of Middleton CBS. It was a very hard fought contest with Sean Twomey and Conor Desmond to name just two of many of our spirited performers. Middleton proved to be very accurate from placed balls, scoring 12 points from frees. The game ended goalless but Middleton advanced to the next round on a final score line of 0:11 to 0:23, having led by only 4 points at half-time. Middleton have since secured their place in the final after they easily dispatched Colaiste Choilm 6:21

to 0:09 which goes to show the quality of the effort our lads produced in the quarter-final.

The senior hurler's next competitive fixture was Tuesday 15th of November, where we travelled to Cobh to play St Coleman's Community College Middleton in order to advance to the last 16 of the Munster 'B' PPS. We had a bright start with points from Cian O'Mahony, Sean Twomey and Luke O'Callaghan. Although we had more possession and territory, the Middleton side never gave up and were still very much in this game thanks to some long range scores from their half forward line. Our lads kept battling and were rewarded with two goals before half-time with Ross O'Donovan and Aaron Lyons both finding the net. It was an extremely physical match from start to finish with Dillon O'Sullivan having a very strong and dominant performance at corner back. It was Kinsale who finished the stronger with points from Aidan O'Donovan, Richard Sweetnam and Cian O'Mahony, and a second goal by Aaron Lyons with 5 minutes left on the clock to ensure we ran out winners on a scoreline of 3:23 to 1:16.

Next we played Colaiste an Spioraid Naoimh Bishopstown for a place in the quarter final. The game was played on Thursday November 8th at Glen Rovers GAA grounds. Colaiste an Spioraid Naoimh started much brighter and had a 5 points to no score lead after 10 minutes. Our lads fought back with a couple of points and in particular a great point in a tight angle from Conor Desmond. The difference between the teams at half time was six points where Spioraid Naoimh proved to be much more clinical from placed balls. The second half was as tightly contested as the first but Spioraid Naoimh managed to maintain a lead throughout. Aaron Lyons was first to pounce on a loose ball around the opposition goal mouth a reduce the deficit but only 2 minutes later Spioraid Naoimh pushed their lead back out and held on for a 10 point victory which did not represent the closeness and competitiveness of the match.

Special thanks to Colm Crowley and Jamie Cronin Of Rebel Og coaching for their work in training teams and assisting the senior hurling managers Mr Madigan, Mr Clancy and Mr Leahy.

UNDER 14 HURLING

KCS Under 14 hurlers have had two matches so far in a group of 5 teams in the Cork Post-Primary Schools 'B' hurling. The first game was against a strong Pobalscoil na Trionoide, Youghal team. Overall the team performed well but Youghal had too much fire power on the day and ran out worthy winners. This was a good first outing where the team learned a lot, which would be valuable experience for further games in this group. On this particular day there were great performances from Sean Walsh and Paudie Dorney.

The second outing came against a good Scoil Mhuire gan Smal- Blarney side with both teams evenly matched throughout. The game was played in an extremely sporting manner, in good hurling conditions in Kinsale GAA. KCS started brilliantly with two quick points from Cian Quinn. Colin Roche, who captained the side on the day and Jack Deasy at full back, had powerful performances which provided a great platform for our forwards. As the game progressed there was nothing between the two sides and a thrilling match ensued. As the game came to a close, Blarney got 3 unanswered points which brought their lead to 5. This proved too much for our team to pull back after such a hard fought game. There were a number of great performances on the day which included Cian Quinn, Colin Roche, Jack Deasy, Rory O'Callaghan and Sean Walsh.

Overall, there have been two good games for the KCS Under 14s with performances continually improving, promising a bright 2017.

Mr Leahy

Lions Club Ideation

In October all 161 transition year students attended the Kinsale Lions Ideation Camp at the Trident Hotel. Ideation teaches young people how to improve their thinking strategies. The Lions Club facilitators, led by Mr Nick Gratten, are experienced, successful business people who agreed to share their time and expertise. The camp is a stimulating learning experience where students improve their creative capacity, find inspiration, learn how to identify problems and build ideas into tangible concepts.

The students worked in their mini company, bank, year book, robot, junk couture groups as this year the camp was focussed on ideating for these ventures. Students from Mr Hayes' class worked on an entry for the "One Good Idea" competition.

Students started by brainstorming ideas, identifying problems that require innovative solutions. The mentors guided the students to understand the needs of their user base. They were encouraged to research smart new technologies or intelligent use of existing technology they could use to solve problems. After selecting a great product idea, the teams then had to decide how to market the product and present their idea to a judging panel.

The day ended with each team doing a "Dragon's Den" style presentation to a panel, "Pitching" their idea with the aid of a poster. It was a challenging experience for all involved and students had the opportunity to develop a wide range of skills such as interpersonal, communication, teamwork, negotiation and research skills.

Many thanks to Ms. Hay, Ms. Brosnan, Ms. Woulfe, Mr. Hayes, Ms. O'Donovan, Mr. McGrath Ms. Crowley and Ms. Murphy for accompanying students and to the Kinsale Lions Club for organising and facilitating another successful and highly beneficial event.



JUNK KOUTURE

Junk Kouture is a national contest which encourages young designers in second level education to create striking couture designs and impressive works of wearable art from everyday junk that would normally find its way into the bin. This competition aims to inspire and ignite passion in these teenagers while at the same time educating them about the importance of recycling and reusing waste. Junk Kouture has established itself as the premier recycled fashion competition for teenagers throughout Ireland and Northern Ireland and in 2015 extended its creative platform to Scotland. A class of 30 Transition Year pupils have been working hard on their unique designs and are beginning to build these elaborate show stopping garments under the watchful eyes of Mr. McGrath and Ms. Kelly. Everything from old coffee pods, straws, make-up wipes, shells and old CDs are being used as materials. The deadline for entries is on the 27th of January so the class are feeling the pressure now! Watch this space!



#GOHISTORY

Photographed are first year students from Ms Dunne's history classes (1A1 and 1A2) presenting their impressive history projects. Students transformed their copies into historical pieces. Themes portrayed included Hilary Clinton's political career, music throughout the decades, women in history and Irish historical sites. Well done to all!



Home Economics

The Home Economics Department have been very busy in the kitchen this term.

Throughout all classes, students were encouraged to take advantage of the seasonal fruits and wild berries which were readily available over the past few months!

1st Years produced Apple Crumble, 2nd Years produced Apple and Berry Tart, while 3rd Years modified queen cake and muffin recipes to take advantage of the wild produce on offer! From the pictures you can see they enjoyed the experience!

At the beginning of October, 2nd Year students were lucky enough to get to go on a trip down to 'Barrett's Butchers' in Kinsale. There, they got to see first-hand the types of meat, cuts of meat and also a real carcass of meat prior to cutting! They were also delighted to get a superb talk from owner John Barrett, who spoke very well on supporting local craft butchers!

We are looking forward to our next trip out to the local Fish Shop in Kinsale, after Christmas!

3rd Year Projects--- 3rd Years are adding the finishing touches to their 3rd Year projects, which will be examined in early April! Well done to all students who have put in a great amount of time & effort into them!!

Also photographed are students practising their sewing skills!



Belgooly Show

Congratulations to the following students who won various entries at the Belgooly Show.

Secondary School Hand Knit Item
1st Olivia Keohane
3rd Kate McCarthy

Secondary School Embroidery / Cross stitch.
1st Jenny Murphy
2nd Abbygail Allen

Homecraft
2nd Enrica Farmer

Embroidery/Tapestry
2nd Cara O'Dwyer



Music

Pictured are students from Ms Kearney's music and choir group who performed at the annual mass for the aged in the Friary as part of Positive Aging Week.



GERMAN EXCHANGE

In October, some of our transition year students hosted their German exchange partners. The students took part in a wide range of activities including a walking tour of Kinsale, a harbour tour that took in the sights of Charles Fort and the surrounding areas, and a visit to the historical Cork City Gaol.

Our German partners also got to experience Cork's famous Shaky Bridge and take part in a game of Footgolf here in Kinsale.

The exchange provides a fantastic opportunity for our students to create links with students from other countries, broaden their cultural knowledge and improve their language skills.

We look forward to making our return visit in March!!



GERMAN SCHOLARSHIP

Earlier this year, twenty-nine Irish students were awarded various scholarships for language courses in Germany by the German Embassy, on the basis of their Junior Certificate German results, and I was fortunate enough to be one of them. However, the twelve of us who were to travel to the small town of Bad Iburg in north-west Germany weren't feeling as fortunate as we should have, assembled for our departure at 4:00am in Dublin Airport in early June!

I had participated in our own Transition Year German exchange with the Goethe Gymnasium in Karlsruhe, and after an amazing experience, I initially wasn't in any way apprehensive about this trip. Only when I was standing in the Aer Lingus check-in line with my dangerously heavy bags, surrounded by people I had met on a single occasion for an hour-long information meeting, and having bid farewell to my teary-eyed mother, did a wave of emotion hit me; I had left behind everything familiar, to venture into a relatively unknown German town for almost three weeks, staying with a strange family with whom I had a brief correspondence via e-mail, to try and improve my standard of German that had been at its peak the previous year, but had slipped to near the bottom of my list of priorities amidst the hustle and bustle of

TY. As I gazed out at the Dublin dawn from the window seat of the plane, it dawned on me; I wasn't as tough as I had thought. Looking back on this moment now, however, I laugh at my naivety. In my seventeen years of existence, some of the best experiences, memories and friends were products of this trip.

We really dove into the deep end at the beginning - quite literally, as some unknown higher power inspired me to jump off a three-metre high diving board on the first day. We spent our mornings and afternoons at the local school, Gymnasium Bad Iburg, attending a mixture of classes with our German guest partners, and our own language course. It was strictly non-stop German, a constant bombardment of new vocabulary, grammar and translations, and within a day or two we were beginning to wilt from the intensity of it all. As the week progressed, however, we found everything becoming more fluent, be it speaking, listening, attempting to understand the discussions on morality in religion class, or complimenting the Year 12s during their rendition of "Townies vs Boggers".

After an intense first week, we were then given the opportunity to put our new



and improved German into practice. We attended their school musical, "Natürlich Blond" ("Legally Blonde" - which, may I add, wasn't a patch on our own "Billy"!), went hiking, had a reception with the local mayor and visited the cities of Osnabrück, Münster, Hannover and Cologne. I was astonished to find how much I could actually understand, be it on public transport, in shops and restaurants or during Public Viewings of the Euro 2016 matches.

Then, to our dismay, just as soon as we figured out how to use the bus without the aid of our German counterparts, just as soon as we found an ATM with an English-language option and discovered where to go for the best ice cream, our time was up. Three weeks went from being too long, to not long enough. After an "Irish Concert" featuring The Siege of Ennis, An Dreolín, The Kerry Polka and of course The Fields of Athenry, we said teary goodbyes to our new German friends who facilitated such

a wonderful trip, and embarked on one last bus journey to Düsseldorf airport.

Comparing the tears shed at our departure from Bad Iburg to those throughout our bus journey, however, was like comparing a dripping tap to a waterfall. It was only on the Autobahn when it hit us; our little Irish group would soon split up and scatter to all corners of Ireland once again. If someone were to ask me what the highlight of this scholarship was, without a shred of doubt, it would be the eleven amazing people I got to share this whole experience with. Never before had I been in the company of so many talented, intellectual people, with passions ranging from Road Bowling to Socialism, speaking six languages, even orienteering and playing basketball on the national teams. Our conversation topics were on an unbelievably and fabulously broad scale, from the Illuminati and the Butterfly Effect to cutting turf and Donald Trump. We laughed together, cried together, got lost together, and made so many wonderful memories, despite our trip being so short-lived, and forged friendships that will last for many years to come. We consisted of Gaelgóirs, bakers,



sport fanatics, linguists, musicians, artists, thinkers and dreamers, and for seventeen days we were family.

This trip was a chance for me to leave my comfort zone far behind and really challenge myself, both academically and personally, and I am so privileged and humbled to be able to join the list of people who have been lucky enough to avail of this once-in-a-lifetime experience.

Fiona Deasy (Y5)



TY students preparing for the annual Kinsale Triclub Santa Dash



TY Volunteers at Santa Dash.

PARENTS ASSOCIATION

Kinsale Community School is aiming to have the reputation of being the “Healthiest School in Ireland.” In the recent past, the school has had national success in multiple sports including basketball and golf. However, the playing field has been frequently waterlogged and unplayable and this has hindered outdoor activity for the students.

As part of the ongoing building works the school is now upgrading the existing sports facilities. The new gymnasium, with a full sized indoor basketball court and a fitness suite, has been completed and will be ready for use in the new year. In addition to this, the playing field has been re-surfaced with FIFA accredited all weather astro-turf.

In the Spring of 2017 a new 5 lane 300 metre running track will be put in place around the outside of the pitch. The semi oval areas at either end of the pitch will be used for tennis and other activities. This will ensure that students will have access to the best quality playing surfaces for both organised sport and informal games throughout the school year.

The school has committed to making the facilities available to the local primary schools and sports clubs, so this will benefit a large number of people in our local community.

This improvement to the outdoor sports facilities is not covered by the buildings grant provided by the Department of Education and Science. The track and

pitch will cost approximately €400,000. The school has already some funds available but there will be a shortfall of approximately €160,000. The Parents Association are currently fundraising to meet this target.

We have started a scheme whereby businesses in the local area have been asked to sponsor a metre of all-weather track for €50 or a metre of the running pitch for €250. We have received great support so far from many of our local businesses. All will be thanked publically in the local press, on a plaque in the school and on our Facebook and Twitter pages.

The sponsored walk raised an excellent €12,000. Well done to all the students and teachers who took part. Kinsale Triclub are going to donate the proceeds of their annual Santa Dash to the fundraising and the Parish Folk Group choir are running a special carol concert on December 16th in St John’s Church to help us to raise the money.

Families with students in the school have been asked to consider making a once off donation of €250. The reason we have picked €250 per family, is that there is a tax rebate scheme, where tax at 31% can be reclaimed by the school on any donation of this amount or more in 1 tax year. If you donate €250 then the school will get an additional €112 making the value of your donation €362.

We know that not every family will be able to spare this amount of money. So, any donation (no matter how large or small) will be gratefully received.

Finally, we will be starting a crowdfunding campaign shortly, to encourage donations

from past pupils, visitors to the area, and anyone with an interest in promoting health and fitness in the young people of the area and the community at large. This will be promoted by email, Facebook and Twitter so we would be grateful if you would forward it on to contacts and give it as many “shares” “likes” and “favourites” as possible!

Donations can be made by sending a cheque directly to Kinsale Community School or by making a lodgement to the fundraising account with Bank of Ireland Kinsale: IBAN IE41BOFI90081821352080.

The fundraising committee is a sub-committee of the Parents Association. The co-chairs are Owen Wills and Jon Hynes. The co-secretaries are Helen Hynes and Rachel Casey, and the treasurer is Tracey Murphy. The other committee members are Christina Broderick, Eddie Kelleher, Samantha Bowen, Eddie McCarthy, Hillary McCarthy, Mariana Lukacova, Debbie McCarthy, Elton Chambers, Cabrini Cahill, Olivia Ormiston, Maggie O’Brien, Breda Shortt and Nuala O’Reilly. We have been hard at work hand delivering letters to businesses. The positive feedback we have been receiving is very encouraging. If you would like to get involved in the fundraising committee, then any help would be much appreciated.

You can email us on kcs.pa.fundraising@gmail.com with any questions. If you are on social media, you can follow us on Twitter: @KCSPA_Fundraise and on Facebook: @KCSParentsAssociation to help us spread our message.

Helen Hynes, Secretary



Literacy visual word puzzles



Give your brain a workout with these word puzzles
Each depicts a well know word, phrase, or something a little more complex!

**Mind
Matter**

Standing

Miss



Blonde



HAMLET
WIN WIN

DEA

÷ **Chestnut**

X

Mascara



STUDENT COUNCIL

This year's Student Council Elections were held once again in the first term. Every single student in the school from 1st to 6th year voted for their Student Council Representatives. There was tough competition in many year groups

with many suitable candidates taking part in this year's elections. It is certainly admirable for students to have the courage and foresight to nominate themselves for election. Well done to everyone who participated in the process. The Student

Council in the school is going from strength to strength and is 27 members strong this year. We are looking forward to representing the student voice once more this year.

STUDENT COUNCIL TRAINING DAY

The Student Council has always had an active role, both publicly and behind the scenes, in representing the student body of Kinsale Community School, and this year was no exception.

With a huge number of students expressing a keen interest in becoming members, elections were held in October, with each year group voting for the nominees they felt would best represent their best interests on the Council.

The product of these elections was a diverse and talented group of students from 1st to 6th year, each individual with their own unique skills that contribute to a very capable, enthusiastic and ambitious student council for this school year.

The group consists of experienced representatives from the senior half of the school – Head Boy and Head Girl, Tadhg Mc Carthy and Niamh Twomey, 5th Years Fiona Deasy, Aliasha O' Shea and David Graham and Transition Years Eve Casey and Daniel Graham – along with confident and enthusiastic junior students who are eager to establish themselves as active and prominent members of our school community; 3rd Years Alvaro Fernandez and Emily Gleave, 2nd Years Alex Lordan, Erika Aigbologa, Jerry Coughlan and Isaac Tobin and 1st Years Aoife Hartnett and Cian Cunningham (1A1), Lily Fitzgerald and Cian Cunningham (1A2), Emer Heery and Darragh Broderick (1A3), Sarah Carroll and Sean Collins (1A4), Ava Mulhall and Conor Green (1A5), Eoghan McGinn and Frank O' Sullivan (1A7), Megan Fahy and Nathan Good (1A7).

The newly-elected Student Council attended a training session with Mr John Murphy on November 22nd in the Trident Hotel, where we got a chance to meet each other and discuss our aims for the year. John gave a presentation on the function and structure of a student council, the different roles of members and the importance and benefits of such leadership activities later on in life. It was an extremely informative morning, led by a man who had a huge amount of knowledge and experience in youth leadership, and we came away feeling very optimistic and ambitious for what we hope to achieve for the months to come.

Fiona Deasy

(Co-Chairperson of The Student Council 2016/2017)



PREFECTS 2016

Being a part of the panel of prefects in our school this year has already been an amazing experience; from the formation to the training and the endless planning. When this current group of 5th and 6th year students came together, we knew very little about one another and there was a clear divide between the two years. Despite having the confidence of the faculty and our own classmates behind us we were unsure of the exact role we were meant to play but fortunately for us, our uncertainties quickly dissipated.

A wonderfully insightful training day was held for us in the Trident hotel, refreshments provided of course, facilitated by none other than Mr. John Murphy. He has been key person throughout the training of KCS's student councils and prefects, not only providing advice but allowing us to become inspired by and truly committed to leaving a positive impact on the school. During this crash course, we learnt about leadership and group skills as well as the more technical matters of running official meetings.

With this motivation and drive instilled in us, it wasn't long before both 5th and 6th year prefects were working side by side to come up with ideas in regards to fundraising for charities and maintaining a positive vibe amongst the student body. On a personal note, it was lovely to see such enthusiasm amongst the groups and the sheer variety of suggestions was astounding.

One important aspect that John urged us to understand was that being part of the Prefects meant that we ourselves had to take charge and use our own initiative if we wanted to achieve our goals for the year. This sense of independence and responsibility is, to me, what makes being on the panel so unique and enjoyable.

As of now, we are currently organising our Christmas fundraiser in the school which requires a lot of preparation but seems like half the work with such a diligent team as this. We attend weekly meetings to keep up to date on the current status of our short-term projects and long-term annual goals. A special mention must go out to Mrs O'Callaghan who oversees our meetings and provides any assistance required. She has been an unrelenting source of support and has never failed to provide an answer to any questions that we may have had.

For any prospective prefects out there, speaking for the whole group, I can wholeheartedly recommend the prefects as something to join during your senior years at Kinsale Community School. Not only do you make great friends but you have a unique opportunity to leave a legacy behind you for other younger students to look up to and admire. This year we have the chance to give back to the school and the students and hopefully we will fulfil these wishes to the very best of our abilities!

Niamh Twomey (Co-Chairperson of the Senior Prefect Team)

The 5th and 6th year prefects of 2016 are as follows:

Grace O'Leary
Aliesha O'Shea
Marie Dempsey
David Graham
Jasmine McShane
Julie Moynihan
Fiona Deasy
Saoirse Hill
Niamh O'Sullivan
Georgia Gould
Killian O'Neil
Niamh Twomey
Tadhg McCarthy
Fintan Ford
Abbie Jeffrey
Hannah Quinn
Aidan Lynch
Paul O'Donovan
Cuan Tobin
Hannah Quinn
Jeremiah Cronin
Katelynn Campbell
Lily Carpenter
Marie O'Leary
Marenza Water
Melissa McCarthy
Mia Kovacs
Natasha Hayes
Paul O'Donovan
Paulina Cisowska
Rachel White
Sheila Kelleher
Aisling O'Donovan



Student Council 2016-2017

LEAVING CERT RESULTS 2016

The 2016 Leaving Cert results in the Kinsale Community School were truly remarkable with almost one in four students receiving 500 points or more and with 46% of students receiving 400 points or more. The results achieved outstrip the national averages by many factors

Ali Hill secured the best Leaving Cert in the school with a whopping 625 points, the maximum number of points available!

The students of the class of 2016 were a phenomenal group of people who excelled in their exams and are now destined to achieve even greater feats in the context of their journey through third level courses. We wish them well!

JUNIOR CERT RESULTS 2016

The Junior Certificate results at Kinsale Community School come hot on the heels of the phenomenal Leaving Cert results. The Junior Cert were just as spectacular where the top ten performers harvested a whopping 77 A's and 30 B's! Eve Casey produced the most outstanding result with 10A's and one B, while Triona Nyhan, Lucy Kelleher, Nia Daly, Niamh Murphy and Enrica Farmer all obtained 8A's.

These spectacular results were achieved through hard work, determination, excellent teachers and supportive parents.



Chaplain's Corner

We've had a busy year so far, with a lot going on. In September we had our opening of the year school mass, celebrated by Fr. Robert, and our liturgy was enhanced by the beautiful singing and music organised by Bríd Kearney. A big thank you to all of the students who volunteered to read or bring up gifts. Thanks also to all teachers who helped out with the preparation – the R.E. department and all those teachers who allowed us to use samples of students' work for our offertory.

POPE JOHN PAUL II AWARDS



The Pope John Paul II Award was created in the Diocese of Derry to commemorate the late Saint John Paul the Great who was so committed to young people and who had such belief and confidence in them. The award has been running in the Diocese of Cloyne for many years, and now also in Cork and Ross. This year the awards are being run on an optional basis for Transition Year students. So far, between 20 and 30 students have signed up, and are excited about the work. It entails voluntary work in the community and getting involved in school and church liturgies. The award is non-competitive, flexible and voluntary and requires an ongoing commitment. There are three categories of award: Gold, Silver and Bronze, depending on the level of commitment. Our students are hoping to achieve the Gold Award.

NEW MEITHEAL TEAM

In May, 10 of last year's T.Y. students went to the Scala community in Blackrock for 4 days of intensive Meitheal training. All of this was to help them to become leaders and to help with the induction of our new first years. So far, they have been doing great work, organising fun



activities which help the first years to settle in and make new friends. They are very dedicated and always obliging, and are a credit to the school and their families.

IN NOVEMBER WE REMEMBER



As we do every year, in the month of November we pause to remember our loved ones who have passed on. Thanks to the creativity and assistance of Ms. Anne O' Leary and Ms. Deirdre Kelly, the T.Y. students made hundreds of hands and leaves for our remembrance tree. The hands represent us, the living, while the fallen leaves represent our family members and friends who have died.

Those whom we love and lose are not where they were before, they are wherever we are. (St. John Chrysostom)

RETREATS

Ms. Callanan took a group of Leaving Cert students for a day's retreat to the Dominican Community at Ennismore in Montenotte. They spent the day in reflection, taking a step back to look at their own lives and also recharge the batteries. Feedback from the students has been positive, and they enjoyed this opportunity to get to know themselves and their classmates a little better. Our T.Y. students will be travelling to Scala

on three different days for their retreat in the middle of December.

ADVENT

Let's face it - the four weeks leading up to Christmas are the worst possible time to try and prepare spiritually for anything. It is a time more attuned to shopping and parties than to greater prayer or reflection. But in many ways that's exactly the point. Advent is not easy and it's not convenient. The word Advent means 'coming'. It is the time of year when we get ready for the coming of the most important guest of all time Jesus. It's a time to pull back from the world just far enough so that we can concentrate on the significant event in a stable two thousand years ago, the coming of Jesus then, the coming of Christ in our lives every day and to prepare to meet Christ who will come again. Brendan has already put up our Christmas tree and our crib, and we are anxiously waiting...

This season of Advent means there is something on the horizon, the likes of which we have never seen before.

So stay. Sit. Linger. Tarry. Ponder. Wait. Behold. Wonder.

There will be time enough for running. For rushing. For worrying. For pushing. For now, stay.

Wait. Something is on the horizon.

(Jan Richardson, artist and spiritual writer)

Mr Pentony (Chaplain)

CAMERA CLUB

The Camera Club continued its success this year and members are growing. Camera Club meets every Tuesday in EO3 and we will be actively recruiting new members next term. If anyone is interested in this very creative pursuit and wishes to develop their skills in this area, please contact Mr Diarmaid O'Donovan.



A Peek - Hugo Jambou



A Sunset Leaf - Emma Meaney



Avalon - Hugo Jambou



Black & White - Emma Meaney



Broken - Luka Phelan



Busy - Katalin O'Regan



Candy Floss - Aoife Allen



Cloud Catcher - Josh Holford



Curious Caterpillar - Josh Holford



Early Morning Mushroom - Abby O'Donovan



Sonorous - Luka Phelan



Spark - Luka Phelan



The Flower - Roman Sanchez



Waiting - Roman Sanchez



Warm Bridges - Emma Meaney



Winter Sunset- Abby O'Donovan



Worry Stones - Katalin O'Regan



Foot Steps - Katalin O'Regan



Indifference - Hugo Jambou



Light Painting - Hugo Jambou



Red Admiral - Luka Phelan



Soldier Bug - Josh Holford



Sonorous - Luka Phelan



The Shard - Patrick Gowran



The World of Lough Corrib - Patrick Gowran



Stopped in Motion - David Carter

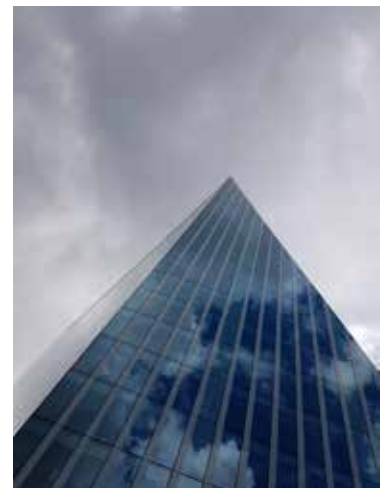

The Office Mirror - Patrick Gowran

BATIK

One of many topics we have covered so far in art is Batik. Batik is where you draw a design on cloth and dye a colour onto it before waxing it to prevent the next colour from mixing with the other dye.

For this batik I tried to use colder colours. I decided that a mountain scape would fit the colour scheme. I first added the white to the cloth by simply just waxing the areas that would be white, then I added the light blue dye to the sky and the lighter side of the mountain. I then applied dark blue to the shadows making sure I waxed before adding the next colour.

Once the batik dried, I crumpled up the piece and then brushed black dye into the gaps. The black appeared like it was creeping through the wax. Eventually I got the mountains.

These are some of the batiks created by Ms O'Leary's second year Art class.

Ben Jordan (Y2)



Alyssa Monkhouse



Benjamin Jordan



Caitlin Kelleher



Camille Le Dreau



Erika Aigbologa



Emma Meaney



Julia Schulz



Rosie Deasy

MURAL

Transition year students Mia Hynes, Abby Egan, Leah Casey, Susan Timmons and Sadhbh O'Brien have been working hard practicing their mural design and painting skills with a project for a local business, Truffle Lodge Cattery. We hope to use these skills in the school grounds when our new building is up and running. The girls did an absolutely fantastic job under the guidance of art teacher Ms. Fitzpatrick.



ART ATTACK

Fifth and Sixth year Art students went on their annual art gallery trip with Ms. Fitzpatrick to the Glucksman in U.C.C to see their present exhibition. "I went to the woods, the artist as wanderer". It is an exhibition by 9 national and international artists including land artist Richard Long.

We had a great tour guide who showed us around the building and exhibition and certainly challenged our understanding of art.



PAINTINGS

A selection of 2nd year paintings done in Ms. Fitzpatrick's class are helping to brighten up the corridors for the festive season. Well done to an expert bunch of painters.



WHERE'S WALLET

As with most jobs, applications and interviews are a must. Six people were chosen to represent the school Bank this year. Those 6 People are Abi Allen (Manager), Andrew O'Connell (Chief Operating Officer), Daniel Graham (Financial Controller), Kate MacCarthy (Customer Service) and Sarah Moynihan (Marketing and Sales Executive).

Our bank name this year is "Where's Wallet". Our overall goal is to be involved greatly in our school community and the wider community also.

We aim to help out in extracurricular activities, we have organised and marshalled the school walk, school bank 'Build-a-Library's second-hand book collection, Kinsale community Santa Dash at Christmas, online banking lessons with the elderly, banking lessons with 1st year student, an introduction to banking with primary schools, the Kinsale St. Patrick's Day parade and much more.



We are launching on Thursday the 8th December, In CO-1 at lunchtime. We have guest stars, Cork hurler Conor Lehane and Cork footballer, the school's very own Mr. Tom Clancy. We will have music, sweets, competitions and of course a bit of craic.

LIGHTS, CAMERA, ACTION!!

It was lights, camera, action in October for a team of 18 TY students who participated in a one day Film Making workshop facilitated by Cork Film Centre and part funded by the Cork County Council. Two professional film makers guided the students through the filmmaking process, helping them to develop a range of transferrable skills leading to the creation of their own "film in a day".

The day was split into 2 halves. The morning consisted of a workshop in film technique where students learned about lighting and sound with plenty of hands-on use of cameras and sound equipment. Students were given enough information to be able to plan a film of their own.

After a busy morning students sat down to put their newly acquired skills into practice to develop a storyboard and write a script for their very own short film. The students proceeded to act, direct and film this short film on the streets of Kinsale. They even did their own stunts! The two film makers took away the finished product to be edited by them along with other films made by schools in the Cork region. If we are successful this film will be screened at a countrywide event 'The 2017 First Cut'. The Youth Film Festival will take place in April and this group will travel for the Schools Day in Youghal. The success of this day has encouraged other students to seek this film opportunity and Miss Hay has scheduled a second workshop to take place later this year.



Poets Corner



Molly Mitchell (Y3) gave the school a great lift with her hilarious entry for the Today FM competition to win €10,000 for your school. Entrants were asked to write a composition about what makes your school so special and why it deserves €10,000. Taking inspiration from the building site all around her, Molly composed a fantastic poem that impressed the people in Today FM so much, they were in contact within an hour to ask Molly to read her poem on national radio. Molly chatted to Ian Dempsey and did a wonderful job.

Unfortunately we didn't get drawn out of the hat for the €10,000, but well done Molly for giving us all such a lift, creating such excitement and brightening up our winter term!

Why KCS is so special to me

Why do we deserve it much more than most?

For our fab school right down on the coast?

We're trying to raise funds, all on our own

But now I'm thinking we may need a loan.

We've walked many miles and pulled in our friends,

Roped in our families, a means to our ends.

We've raised lots of money, but not nearly enough.

We're begging you now, we're finding it tough.

Construction's so noisy outside every day

There's no peace to study, no room to play.

*We dream of a track, an all-weather pitch
Right now we're stuck with some muck
and a ditch.*

*We've students and sportsmen and
scientists galore
With better facilities we could develop
much more.*

*We'd have labs and canteens and space
to move 'round*

*No longer like sardines, wouldn't that
just be sound?*

*Matt Cooper's from Cork, he's like me
and you!*

*Bring Ian and Mario, the Today FM
crew!*

*Bring Anton and Dermot and Dave and
Paul Mc,*

*Louise, Hector & Fergal. We'll all have
great craic!*

*Kinsale students and teachers will
welcome you down*

*To the west coast of Cork, the most
beautiful town.*

*You'll see we deserve it; we'll all have
great fun*

*We'll head to the beach once the
homework is done.*

*Have you heard all I've said? What more
can I say?*

*K.C.S. is the best, so choose us today!
If you gift us with money, with all of ten
grand,*

*There'll be some party, boy – the best in
the land!*

GEOGRAPHY FIELD TRIP

On Thursday 15th September, two Leaving Cert geography classes set off in woolly hats and wellies to Garrylucas Beach to carry out their fieldwork project.

When we arrived at the beach it was clear that it was going to be a challenging day. Fog had descended like it never had before; we could barely see two feet in front of us, not to mind to say ‘observe’ anything as it asks us to in the booklet. A running joke for the day was “Observation? Fog. Trouble? Unable to observe due to fog.”

We had a number of activities to fulfil before the end of the day. Firstly, we had to measure slopes and angles from the top of the beach right down to the sea. Picking up samples of rocks was another, and drawing a profile of the beach (which again was quite tricky due to our ‘trouble’ of the fog).

Probably the most entertaining part of the day was throwing oranges into the sea to prove a process called long-shore drift happens. Unfortunately the oranges needed to be thrown quite far out to ensure they wouldn’t come back to shore too early. I was handed an orange, along with four or five others. A couple of the lads got them out pretty far. Mine, on the other hand, was not long returning to me or the sand. I still haven’t heard the end of that one.

It was a lovely surprise to find that rather than returning to school for the rest of the day, we had been booked into the Function Room in Actons by our generous principal, Mr. McCarthy.

Overall, we had an amazing couple of days and it was definitely a lovely addition to an overall tough year we have ahead. I’d like to say a huge thanks to both of our amazing teachers, Ms. Hayes and Mr. Madigan for making it such an enjoyable day.

Maebh Delahunty (Y6)

NUJEEN MUSTAFA



An inspiring Skype interview with Teenage Refugee Nujeen Mustafa took place on Friday 14th October with a group of excited TY students and their teacher Ms Brosnan. The event was moderated and organised by Padraig Fitzgerald of Kinsale Peace Project. It was a unique and memorable occasion; with Kinsale Community School being the first school in Ireland to take part in such an interview with Nujeen.

At the age of 16, Nujeen left Aleppo with her sister and made the treacherous journey by boat to Greece. Here they were kept in a detention camp before making the long journey by foot and bus on towards Germany. The sisters were stopped by Border Guards of various not so welcoming countries before she finally made it to Cologne to meet her brother where she now lives.

Her amazing story has been shown on BBC and CHANNEL 4 and she has now co-written a book with international journalist Christina Lamb, who worked with Nobel Peace Prize winner, Malala Yousafzai.

It was a fantastic informative day. Students also had the opportunity to take part in a question and answer session and got to know Nujeen’s amazing resilience despite her suffering from Cerebral Palsy and being confined to a wheelchair.

Over €400 was raised on the day for the Trocaire Syrian Appeal. Well done to all! A special word of thanks to Padraig Fitzgerald and Kinsale Peace Project for organising this wonderful and truly inspirational event.



Third prize presented by Pádraig Dalton, Director General, Central Statistics Office.
Students: David Daly, Ryan O’ Sullivan Teacher: Shaun Holly Kinsale Community School Kinsale Co. Cork

GAA REPORT

SENIOR BOYS FOOTBALL

The senior footballers had a disappointing day out against Colaiste Ghobnatain Ballyvourney in the first round of the Munster PPS championship. Despite fielding an understrength team due to injuries the team gave a very good account of themselves and despite great effort failed to score the equaliser that would have forced the game to a replay. Final Score: Kinsale Community School (1-9) Col. Ghobnatain (2-7) The Cork PPS championship against Mitchelstown CBS will be played in January.

U14 BOYS FOOTBALL

The U14 team have been training every Tuesday and will begin their campaign in January. We have had very big numbers out with 40 plus players at all trainings. Long may it continue.

U15 BOYS FOOTBALL

This group of players have been having a great season by and creating a bit of history along the way by being the first team from the school to contest a Munster final. They began their campaign with an facile win against Colaiste Dun Iascaigh Cahir on a score line of (1-4) to KCS (1-19). The quarter final pitted us against Killarney Community College and it was goals galore in this game with the team recording another big win on a score line of (3-3) to KCS (12-16). The semi-final was fixed against Presentation Milltown, Kerry. This proved to be a huge test for the lads with the lead being swapped at numerous stages during the game. It is said that goals win games and we got ours at the right time with a goal in the final minutes to seal a great



U16 County Football Champions 2016

win and a two point victory. Final score: Kinsale Community School(5-5) V (3-9) Presentation Milltown.

The final was again against Kerry opposition with Phobail Scoil Kenmare being the opposition. Despite putting in a huge effort on the day we could have no complaints and were beaten by an excellent team in Kenmare. Final score: Kinsale CS (4-4) Inver Sceine Kenmare (3-16) Despite the loss this team has really improved their football and are competing at a very high level as well as competing in two finals in the last two years. There is huge talent coming into

the school from the local clubs and with continued hard work both school and club should benefit.

Panel: Colm Madden, Eddie Corkery, Jack Roche, Jayden Healy, Jamie Linehan, Jack o Donovan, Michael Murphy, Charlie Granger, Jack Hemlock, Liam Healy, Matthew Healy, Colm Burke, Darragh Kidney, David Higgins, Kealan O Rourke ,Eoin Redmond, Paudie Dorney, Luke Desmond, Cormac Kelly, Evan Wrenne, Brian White, Charlie O Shea, Paul O Riordan, Declan Doyle, David Daly, Rory McCarthy, Paul Graham and Colin Roche.



U15 Football Panel

KINSALE LADIES GAA

2016 proved to be the most historic year ever in the whole of the Kinsale GAA club. It's hard to believe that we've come from losing a county final in 2015 which gave us the determination to reach the Junior A All Ireland. Our season started in a very muddy pitch in Dunderrow. That day you could see the determination in all the girls and it made us realise that this year had the potential to be a successful year.

We travelled far and wide in the County of Cork in the Spring and Summer and finally reached the County final. We had to wait several weeks as our Cork senior, Orla Finn, had to play her All Ireland final. Eventually, two days after the All Ireland senior final, the Kinsale Juniors took the road to Mourneabbey in hope that they would be County Champions. Here an exhibition of football was given. There was some crisp hand passing and accurate foot passing with scores galore and very few wides. The final score was 4-17 to 1-14. Celebrations were put on hold as our Munster Quarter Final was only days

away. We played the mighty Austin Stacks from Tralee on the following Saturday. Going into a Munster Quarter Final, we never dreamed of how far we could get or how close our team would become and grow together. We were quite fearful of the opposition as they had many inter-county players. Once again, after a very intense performance of football, Kinsale managed to come out on top. Our next destination was Mallow where we played Dungarvan in the Munster semi-final. We wore the Cork u21 jerseys as there was a colour clash between our two teams. Once again we gave an outstanding

performance on the field where the final score was 7-13 to 4-9 to Kinsale. We knew that the Munster Final would be one of the most challenging matches all year as the standards were getting much higher. The Drombroadford team were certainly the fittest team we had come across as they had many of the Milford Senior Camogie team playing with them. As expected it was undoubtedly the most intense game of football we played all year but in the last ten minutes we pulled away to a glorious victory of 0-17 to 1-10. There were big celebrations in Kinsale that night as we were the first Kinsale team to become Munster Champions.



Kinsale Ladies Munster Champions

On the 19th of November, we travelled to Castlebar in Mayo as a team. We found this to be a great bonding experience when we stayed overnight in the Breaffy Woods hotel. The next day we travelled to Ballina to face Kilmoremy who had many inter-county players. People say that our performance that day was the best they have ever seen Kinsale Ladies play. At half time we were only ahead by three points but at the start of the second half we pulled through by scoring two quick goals and by the time Kilmoremy got a penalty it was too little too late. Cramps set in all at once to many players but we knew we had the game in the bag at that stage. When the final whistle was blown, the crowd from Kinsale cheered us on as we jumped for joy. As a squad we felt that

it was necessary to go over to the stand to thank all the supporters who travelled to Mayo to see us play. Travelling home from Mayo was filled with celebrations as we realised we were All Ireland finalists.

It wasn't long before training began again to prepare for the All Ireland final. Excitement built around the town with blue and white banners and decorations outside businesses. Blue and white Santa hats were being sold with all donations going to Autism Ireland. Nearly 300 Santa hats were purchased by supporters of Kinsale. The day of the All Ireland final we travelled to Carlow town, to Dr Cullen Park. Nerves came from both teams as they ran out onto the pitch. After a difficult first half when we lost

injury, and going 7 points down, we realised we had to come out in the second half with all guns blazing. In the second half, you could see the determination in our play like we had in our first game in Dunderrow. After many attacks from Kinsale we brought the score back to a two point difference. Unfortunately our crazy rollercoaster ended. Although, we raised our heads high and realised we left everything on the pitch. This is what makes a team, a belief that no matter how hard you fall you get back up together and go again. Because a great team is not about one game, or even one season, it's about the journey it takes to get there.

Niamh Cronin, Jenny Murphy & Juliette Cronin, TY

LADIES GAA

The senior ladies team have reached the Munster C semi-final and will play St. Flannans, Ennis. They had comprehensive wins over Coláiste na Toirbhirte, Bandon & Mount St. Michael, Rosscarbery in the group stages.

Congratulations to Tracy McCarthy, Georgia Gould & Sadhbh O Leary who have been selected on the Munster panel to represent KCS in the Post Primary Interprovincial blitz which will take place in Kinnegad, Co. Westmeath on Jan 21st.

Pictured is the First year girls team who had mixed fortunes this term. In the group stages, they beat North Mon AG but lost out to Mount St. Michael, Rosscarbery and were knocked out in the quarter final on a freezing cold Monday by Coláiste Mhuire, Buttevant. We hope to see many of these girls on the Junior team later this year.



Y1 Ladies Football Team

WEST CORK GARDA YOUTH AWARDS

One of our very own students was honoured for their contributions to their local communities at the West Cork Garda Youth Awards which took place in November. The West Cork Garda Youth in association with SuperValu presented the awards celebrating outstanding young people between the ages of 13-21 years. These awards recognise that a lot of good work is being done by young people in every community throughout West Cork. Each year a number of young people are recognised for their achievements in a variety of categories. Overall there are 11 awards in total – 5 overall awards, 4 district awards, one group award and one special achievement award.

The entire school community were delighted to hear that transition year student Andrew O'Connell was one of six recipients of the Special Achievement Awards. Andrew has been an active member of his local Foróige Club in Riverstick for the past 6 years.

He has served as an officer in the club since joining and has been involved in numerous community projects. Also, Andrew has been actively involved in projects within the school such as coaching junior basketball and is now training to become an official basketball referee.

Congratulations to Andrew on winning this award and for his outstanding contribution to our local community.



SPANISH TY FIELD TRIP

The Spanish students in Transition Year along with Mr Madigan and Mr Leahy took a very beneficial trip around Kinsale on Thursday the 20th of October. The group were greeted by glorious sunshine for the trip which began with a trip to the Signal Tower and Lusitania Museum at the Old Head of Kinsale. Here, we were given a guided tour by Jerome Lordan, where he gave us a brief history of the Tower and its uses. Along with this the students were afforded the opportunity to learn about the ill-fated journey of the Lusitania and how it came to rest 11 miles off the coast of the Old Head. After this the students and teachers took a very scenic walk to the beach at Garrylucas, where the students learned about the distinct Irish coastal landscape and how the coast particularly around Kinsale has gotten its natural beauty.



After this lesson and a game of soccer where it was the Spanish students turn to give the teachers a lesson, we took a bus back to Kinsale and more particularly to Charles Fort. We were again given a guided tour and the students learned of the very interesting history that the Fort has. The students were lucky enough to get to wander through the Fort and learn of the different aspects that made it such an impenetrable fortress.

Overall, the fieldtrip was one which offered a great deal of learning in terms of the geography and history of Kinsale. This allowed the Spanish students to learn a great deal about the area in which they have been staying for a number of months. It was a very enjoyable experience for both the students and teachers involved.

Mr Leahy and Mr Madigan

Lilly Science Day

Photographed are first year students who participated in a fun filled day performing science quizzes and a murder mystery on November 19th to celebrate Science week.



Mr Fred Rosehill R.I.P

We were greatly saddened to learn of the recent death of a great friend of Kinsale Community School- Mr.Fred Rosehill. Mr. Rosehill was Chair of the Trustees of the Cork Hebrew Congregation and guided Leaving Certificate Exam Religion students on many visits to the Synagogue in Cork ever a ten year period. He warmly welcomed us on each occasion and shared fond memories of swimming in Garretstown, and he reeled in and enthralled his audience like any good storyteller or seanchaí.

Maurice Cohen, Chairman of the Jewish Representative Council of Ireland said the late Mr Rosehill kept the memory of Jewish Cork alive and vibrant “By

telling the story of the Cork community to countless schoolchildren.”

Since 2004, Kinsale Community School students were privileged to have a first-hand experience of visiting and learning about the place of worship of Cork Jews and of hearing about the history of the community in Cork.

Each visit was an experience that was valued by all students and teachers who were privileged to have this opportunity.

On more recent visits Mr Rosehill was accompanied by his grandson Daniel, this added an extra dimension to our students’ experience of witnessing the reality of a living religion as opposed to course content for an examination.

Sadly the Synagogue

closed earlier this year.

On a personal note, I will remember Mr. Rosehill as a man who was kind, open and welcoming. He was generous with his time, gave so much of himself and offered guidance and advice to us and was always greatly interested in our students.

Ar dheis Dé go raibh a anam

Ms Anne Kelly

Untitled

*When I look at myself there's something missing,
And I still haven't found it yet,
But I know when I look and carefully listen,
That is not something I'll regret.
It used to be there before
If only it could flow through my door,
At times when you really need it
The most people just knock it off more.
It's a certain thing that some people have
And it makes them stand out.
It gives you a boost and you don't feel shy
The words just flow through your mouth.
It helps you achieve your greatest dreams
And makes them all come true.
But now, I realise the only person
That controls your confidence is you.*

Enrica Aigbologa (Y2)



Puzzle Page Solutions

Literacy visual word puzzles

Solutions

1. Mind over matter
2. A big misunderstanding
3. Apple pie
4. Fair and square
5. Play to win
6. No Idea
7. Divide and conquer
8. Kiss and makeup
9. Feeling under the weather



Puzzle time

Highest total! - answer

The route shown gives a total of 37.

Can you find an even bigger total? There is at least one way to get 39!

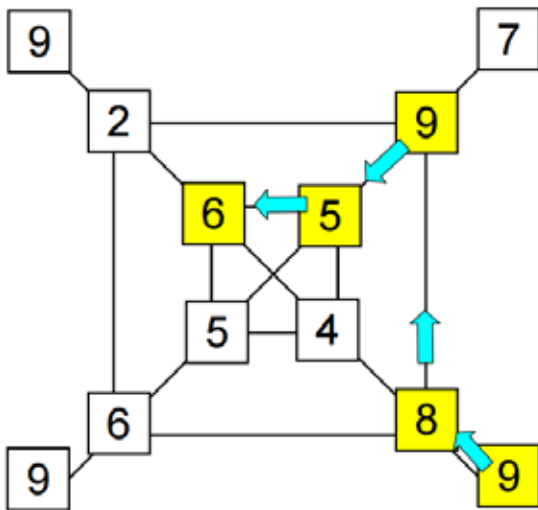

Puzzle time

Christmas tree

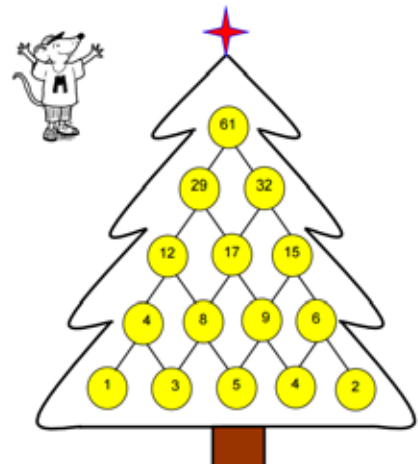

To get the highest possible total at the top you needed to put the numbers in following these rules:

1 and 2 at the ends and 5 in the middle. There are several ways of doing this, including the one shown above.



Puzzle time

Not three in a line - answers

You can place a maximum of six counters in a 3 x 3 grid without getting three in a row.

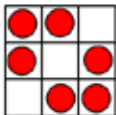

There is more than one way of arranging these 6.

You can place a maximum of eight counters in a 4 x 4 grid without getting three in a row.

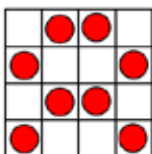

Puzzle time

Seven-up!

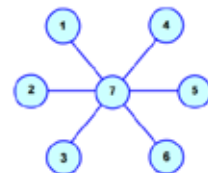

These lines all add up to 14



I expect you found this one not too tricky. And no wonder! There were several different ways of doing it!

Amazing eh, but you could have 7 in the middle, or 4 or even 1.

I've shown you one way above, can you work out others?

New Building Works



Selection of photos of building works taken by Lorcan O'Brien (Y5)

VEX Robotics

STARSTRUCK is the name of the year's VEX Robotics competition but at the first scrimmage of the season in Bishopstown GAA hall the TY robot aka "Ann Droid" was anything but starstruck. The competition challenges teams to build a robot, program it and drive it to score as many stars and cubes in the opponents zone. Since the middle of October the TY robot team has been busy learning how to build this robot. The 30 strong team each have their own area of expertise. Some are building an arena so we can practice driving our robot in an arena resembling the competition. Some students are working on PR and marketing and raising sponsorship money to fund buses and new parts for the robot. Some students have created a website and facebook page to develop our robot identity. A number

of students are learning how to code in ROBOTC and are gaining new skills coding in a virtual robot environment.

The main robot build team dismantled last year's robot, did a complete stock take ordering replacement parts and then put together their own clawbot for the first competition. The project managers in the group are documenting the entire design process as they go through iterations of the design. Mr Corcoran, Mr Farrane and

Miss Hay along with Adrian McLaughlin from EMC DELL have mentored the students throughout this competition as they learn lifelong skills in teamwork, leadership, communications, project work and more. The second phase of the build will commence in December, starting with a trip to a robotics factory in Kilbrittain where the team will hopefully get some inspiration for their final design for the Vex Robotics Final being held in CIT end of January.



***Congratulations to our Senior Camogie Team
County Champions***

